

Cutting modules

for a wide range of applications

Numerous studies have proven that coloured and personalized mailings with an individual contents are the best way of emphasizing the quality of the advertised product. Hence the response rate is considerably increased. An appealingly designed mailing is an eye-catcher. The right technology attracts the recipient's attention and is therefore the basis for the success of a mailing campaign. With additional devices such as cutting modules, these requirements can be optimally implemented.

Different cutting modules for continuous or timed cutting, perforating and scoring are available for this purpose. The systems are equipped with their own drive and are mobile as well as height-adjustable. They can therefore be integrated in any position at folding machines and other systems.

The sheets are fed into the cutting device by means of a roller table and aligned with an alignment rail. The cutting modules allow the use of knives mounted on shafts with a diameter of 35 mm.

Rotary scoring and cutting machine SM 50 / 2 - HT

- Mobile and height-adjustable
- 2 pairs of knife shafts under a clear acrylic glass cover
- Roller table RT 52 / R 40
 - Infeed width: 80-540 mm
 - Infeed length: 180-1,000 mm
 - Roller diameter: 40 mm
 - Balls diameter: 35 mm
 - Roller gap: 46 mm
 - Available in left-hand or right-hand configuration
- Own electrics for independent control
- Connection with transport systems
- Either GUK- or Tri-Creaser-tools can be used
- Wide range of optional equipment

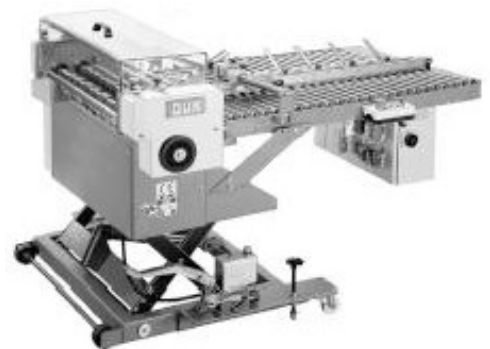

Rotary scoring and cutting machine SM 70 / 2 - HT

- Mobile and height-adjustable
- 2 pairs of knife shafts under a clear acrylic glass cover
- Roller table RT 72 / R 40
 - Infeed width: 80-740 mm
 - Infeed length: 180-1,000 mm
 - Roller diameter: 40 mm
 - Balls diameter: 35 mm
 - Roller gap: 46 mm
 - Available in left-hand or right-hand configuration
- Own electrics for independent control
- Connection with transport systems
- Either GUK- or Tri-Creaser-tools can be used
- Wide range of optional equipment

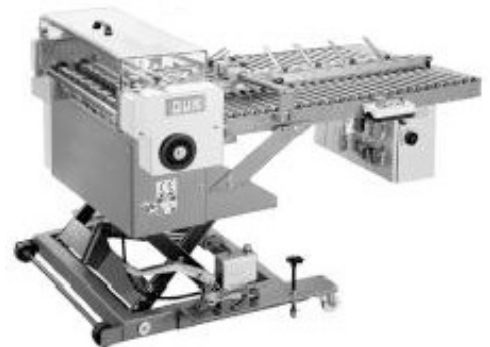

Cutting modules

for a wide range of applications

Rotary scoring and cutting machine SM 54 / 4 - HT

- Mobile and height-adjustable
- 4 pairs of knife shafts under a clear acrylic glass cover
- Roller table RT 52 / R 40
 - Infeed width: 80-540 mm
 - Infeed length: 180-1,000 mm
 - Roller diameter: 40 mm
 - Balls diameter: 35 mm
 - Roller gap: 46 mm
 - Available in left-hand or right-hand configuration
- Own electrics for independent control
- Connection with transport systems
- Either GUK- or Tri-Creaser-tools can be used
- Wide range of optional equipment

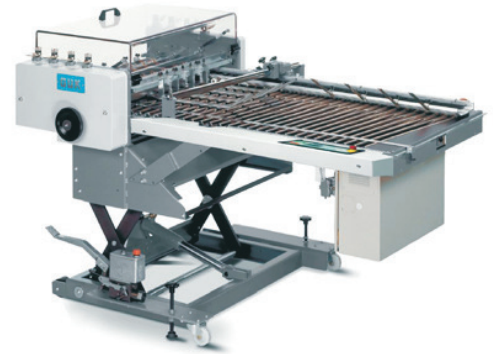

Rotary scoring and cutting machine SM 74 / 4 - HT

- Mobile and height-adjustable
- 4 pairs of knife shafts under a clear acrylic glass cover
- Roller table RT 72 / R 40
 - Infeed width: 80-740 mm
 - Infeed length: 180-1,000 mm
 - Roller diameter: 40 mm
 - Balls diameter: 35 mm
 - Roller gap: 46 mm
 - Available in left-hand or right-hand configuration
- Own electrics for independent control
- Connection with transport systems
- Either GUK- or Tri-Creaser-tools can be used
- Wide range of optional equipment

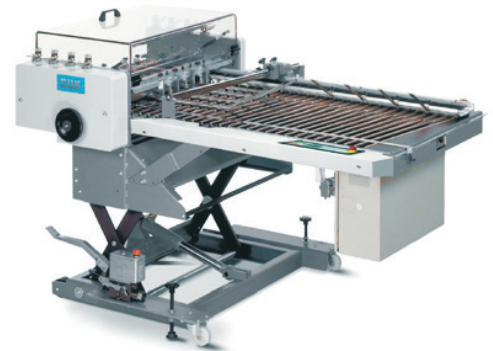

Rotary scoring and cutting machine SM / SA - 50 / 2 - HT

- **Cutting machine SM 50 / 2 - HT**
- Mobile and height-adjustable
- 1 pair of knife shafts under a clear acrylic glass cover
- Own electrics for independent control
- Connection with transport systems
- Either GUK- or Tri-Creaser-tools can be used
- Wide range of optional equipment
- **Infeed section SA 50**
- Incl. control
- Incl. front and lateral alignment, pneumatic
- 1 pair of pressing rollers (feed roller) with rubber rings



Technical improvements may be introduced without previous notice.

